

## Foot Mounted Electric Wire Rope Hoist

### Hoist model VAT5522TpE3N

Capacity - 16 tonne in FEM9.511 - 2m

Lifting Height - 9m

Lifting Speed - 4.8/1.2 m/min

Voltage Supplies - 220, 460, 575V-3ph-60Hz

Rope Reeving - 4/1

Optional thermal overload protection (Tp)

Mechanical overload protection (OL)

Electric panel not shown

Net Weight - 995kg

### Lifting Motor model KV5001-24/6Tp

Rated power - 3.6/15.6 kW

Switches per hour - 240h-1

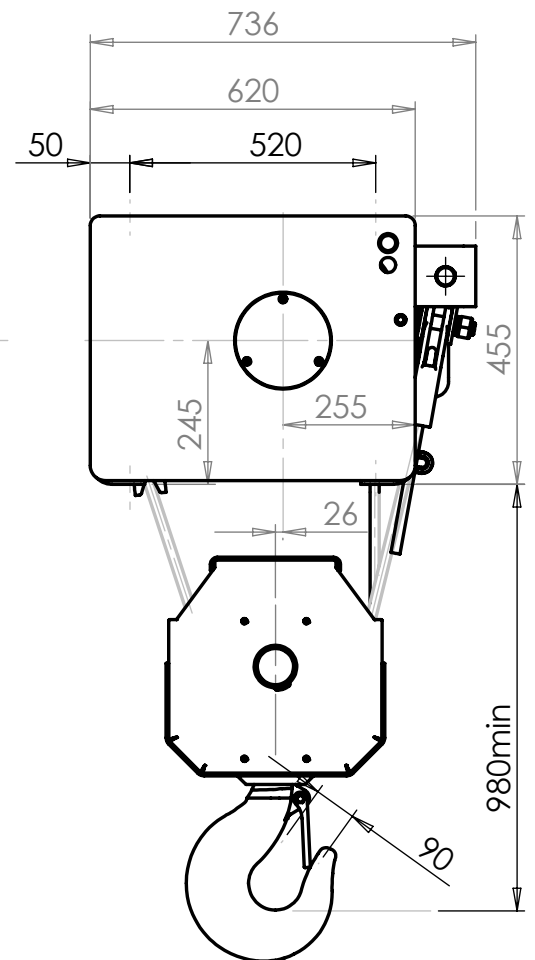
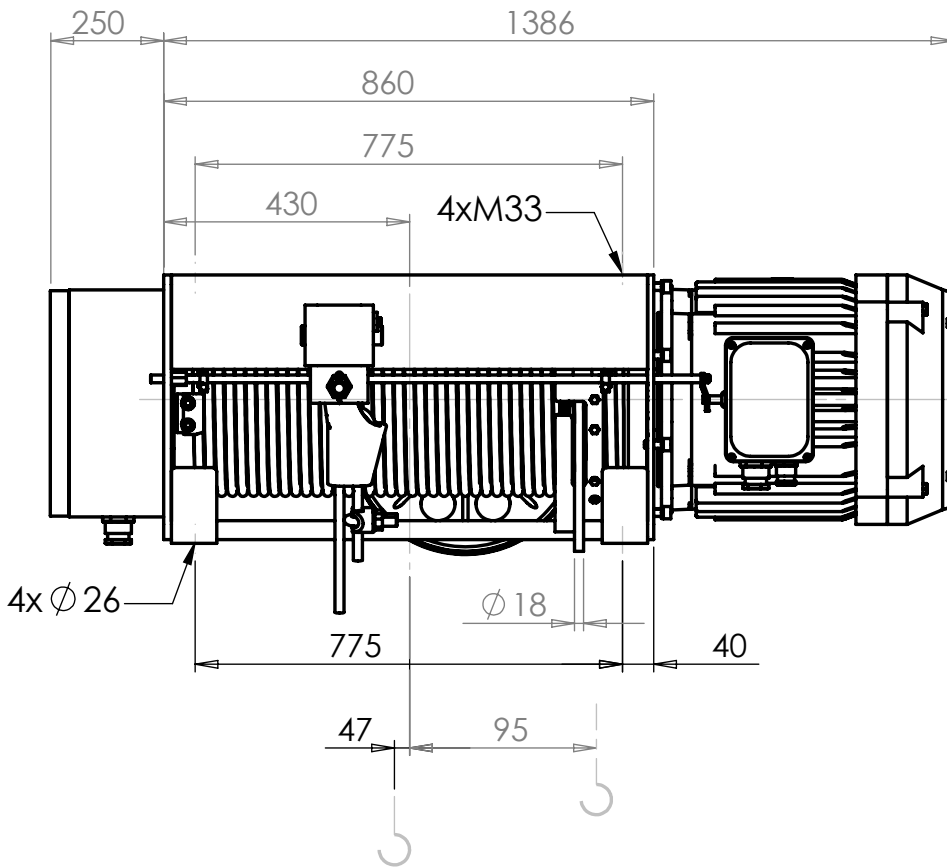

t 604 796 9221  
f 604 796 9227

e integrity@hydramachcrane.com  
www.hydramachcrane.com

\*Dimensions and specifications subject to change without notice.